

PRODUCT INFORMATION PACKET

Model No: 048A11O2028
Catalog No: X063
3/4,1075,OPAO,48Y,1/60/208-230
Direct Drive



Regal and Marathon are trademarks of Regal Beloit Corporation or one of its affiliated companies.
©2018 Regal Beloit Corporation, All Rights Reserved. MC017097E



Nameplate Specifications

Output HP	0.75 Hp	Output KW	0.56 kW
Frequency	60 Hz	Voltage	208-230 V
Current	5.7-4.5 A	Speed	1075 rpm
Service Factor	1	Phase	1
Efficiency	65.7 %	Duty	Continuous
Insulation Class	B	Design Code	NO DESIGN CODE
KVA Code	C	Frame	48Z
Enclosure	Open Air Over	Overload Protector	Automatic Lock Rotor Only
Ambient Temperature	40 °C	Drive End Bearing Size	6203
Opp Drive End Bearing Size	6203	UL	Recognized
CSA	Y	CE	N
IP Code	10		

Technical Specifications

Electrical Type	Permanent Split Capacitor	Starting Method	Across The Line
Poles	6	Rotation	Fixed Counterclockwise
Mounting	Round - Extended Studs	Motor Orientation	Horizontal
Drive End Bearing	Ball	Opp Drive End Bearing	Ball
Frame Material	Rolled Steel	Shaft Type	Special Extension Both Sides
Overall Length	20.00 in	Frame Length	5.00 in
Shaft Diameter	0.500 in	Shaft Extension	7.81/6.69 in
Assembly/Box Mounting	F1 Only		
Outline Drawing	A-SS403654-500	Connection Diagram	6906495

This is an uncontrolled document once printed or downloaded and is subject to change without notice. Date Created: 10/08/2018

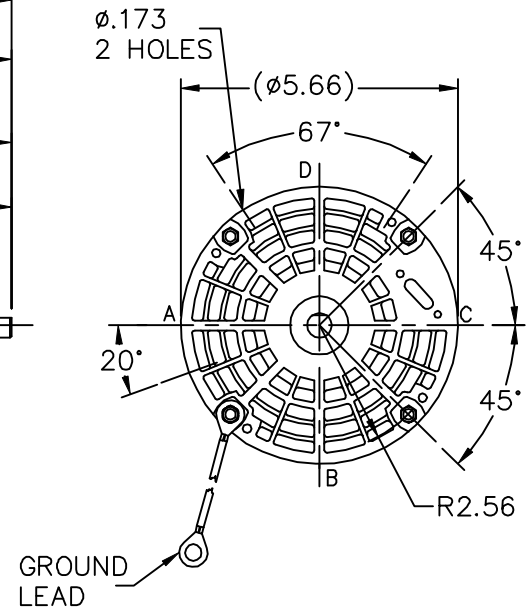
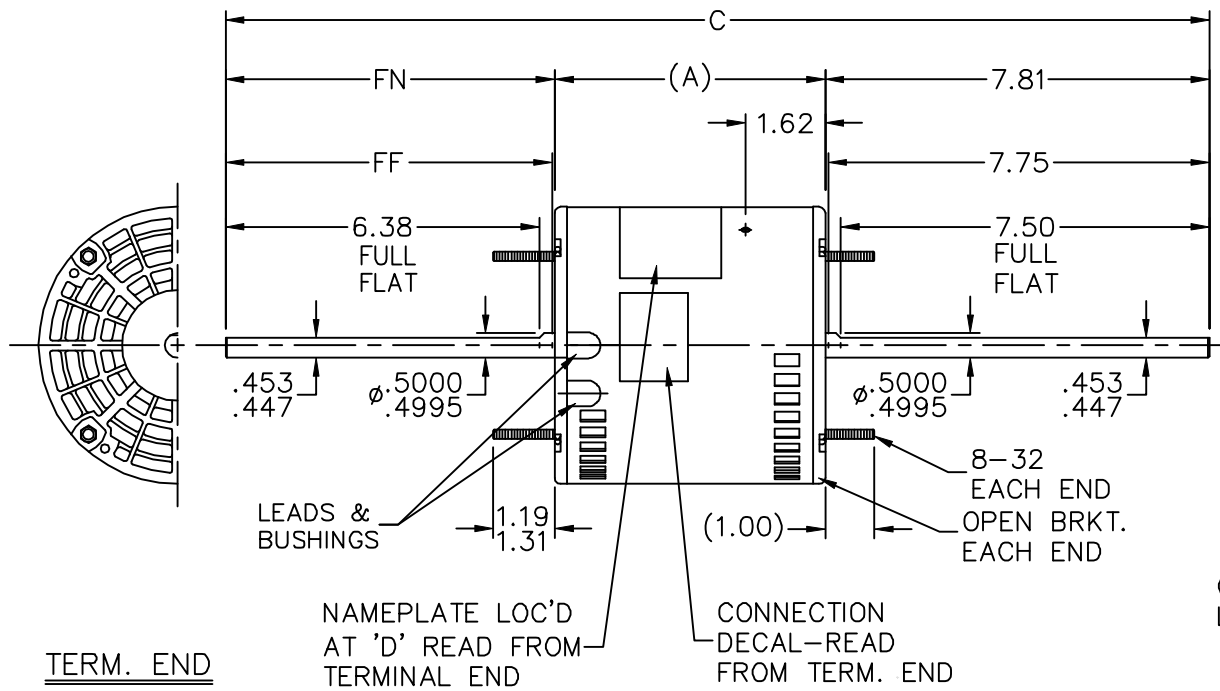

TERM. END

DASH	FR.	C	A	FN	FF
500	48Y	20.00	5.50	6.69	6.64

LEADS DESCRIPTION:

4 LEADS WITH .50 BARE WIRE STRIP
30.00 LONG WHITE, BLACK, BLUE, RED

2 BROWN LEADS WITH .25 FLAG-TYPE
QUICK-30.00 LONG BROWN LEAD WITH
WHITE MARK IS COMMON TO WHITE LEAD

GRN. GRD. LEAD W/ TERM. FOR #10
SCREW 12.00 LONG

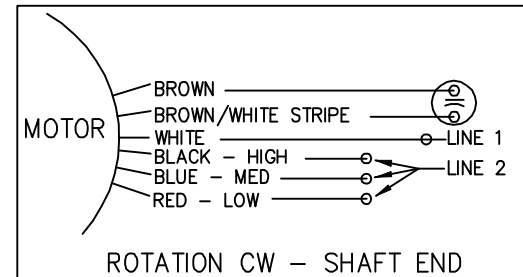

NO.		REVISION	BY & DATE	CHK	ANG	FINISH	MARATHON ELECTRIC		DRAWN	SP 11-19-2007					
				DEC.	INCHES	TOLERANCES UNLESS SPECIFIED	TITLE OULTINE		CHK	NB 11-19-2007					
				.X	±.1				APPD	NB 11-19-2007					
				.XX	±.03				SCALE	9=32					
				.XXX	±.005				REF	SS400357					
				.XXXX	±.0005		MAT'L.	FMF	07-2082						
					±7'30"			PREV							
THIS DRAWING IN DESIGN AND DETAIL IS OUR PROPERTY AND MUST NOT BE USED EXCEPT IN CONNECTION WITH OUR WORK ALL RIGHTS OF DESIGN AND INVENTION ARE RESERVED THIS IS AN ELECTRONICALLY GENERATED DOCUMENT - DO NOT SCALE THIS PRINT							RFP	11-19-2007	CAD FILE	ss403654	SIZE	DRAWING NO.	PAGE	OF	REV.
							DIST	WP			A	SS403654			

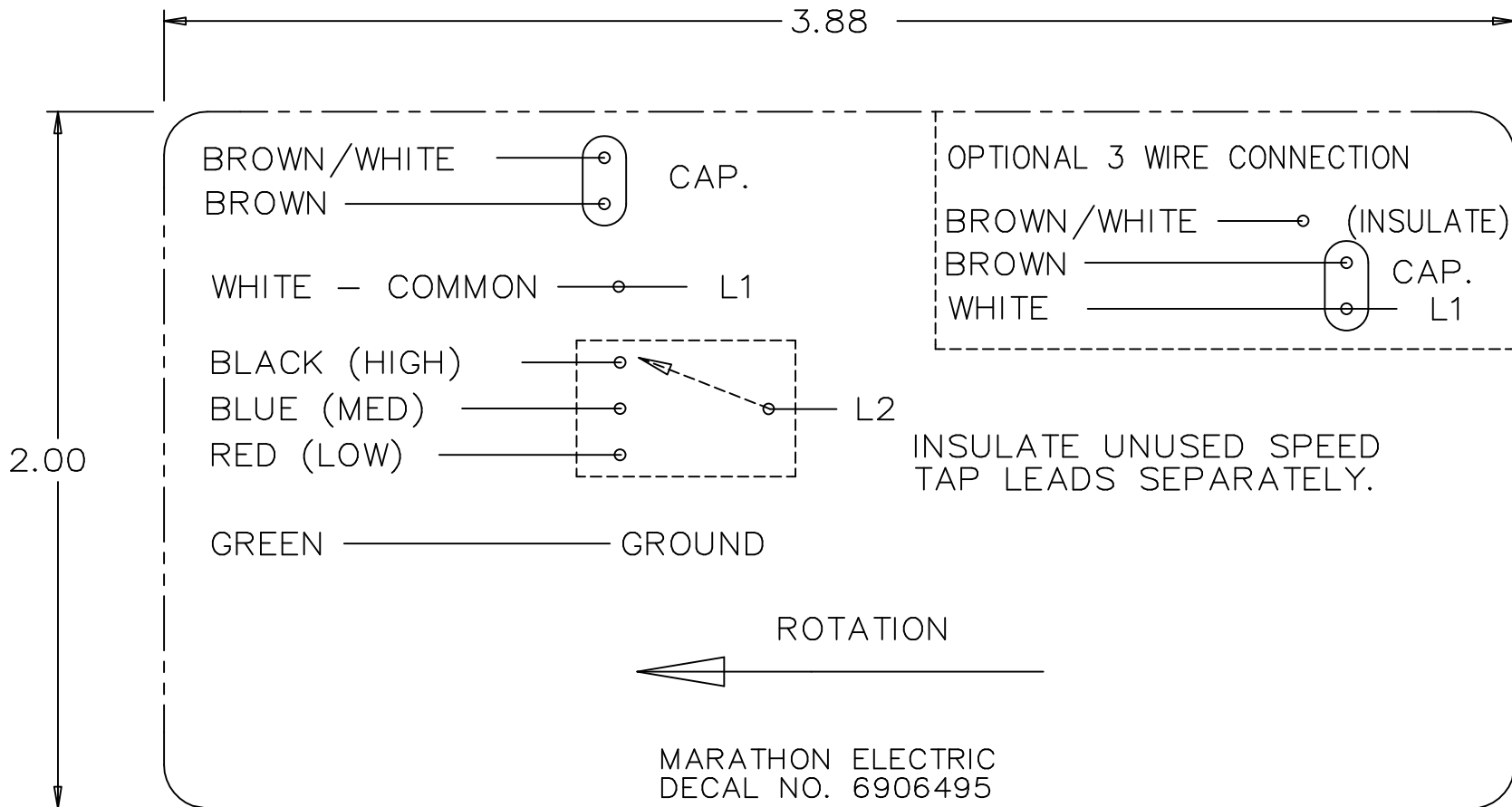

				TOLERANCES UNLESS SPECIFIED		REGAL-BELOIT <i>Motor Technologies</i>	DRAWN MRB 04-16-1998		
				DEC.	INCHES		CHK	ML 04-22-1998	
				.X	±.1	TITLE CONNECTION DECAL	APPD	GK 04-22-1998	
3	REMOVED 'MARATHON ELECTRIC' CN 35106	DRS 05-01-2002	TOM	.XX	±		SCALE	1=1	
2	PART NAME WAS CONNECTION DIAGRAM CN 25669	MRB 04-23-1998		.XXX	±.005		REF		
1	NEW DRAWING CN 25669	MRB 04-22-1998		.XXXX	±.0005	MAT'L.	FMF		
NO.	REVISION	BY & DATE	CHK	ANG	±	FINISH	PREV		
THIS DRAWING IN DESIGN AND DETAIL IS OUR PROPERTY AND MUST NOT BE USED EXCEPT IN CONNECTION WITH OUR WORK ALL RIGHTS OF DESIGN AND INVENTION ARE RESERVED THIS IS AN ELECTRONICALLY GENERATED DOCUMENT - DO NOT SCALE THIS PRINT			RFP	CAD FILE 6906495			SIZE	DRAWING NO. PAGE OF	REV.
			DIST	WP			A	6906495	3

```
ERROR: syntaxerror  
OFFENDING COMMAND: --nostringval--
```

```
STACK:
```

```
/RS  
-dictionary-  
/Pscript_WinNT_Compact  
-dictionary-
```